

Anodising Titanium Instructions

Introduction

When a layer of titanium dioxide is present on the surface of some titanium metal, light falls on the surface and scatters to make the layer look coloured. The colour we can see depends on how thick the titanium dioxide layer is.

In this experiment we will '**anodise**' (**coat with an oxide layer**) some titanium metal to create a titanium dioxide layer and control the thickness by varying the voltage, and therefore the colour.

Materials and Equipment

titanium metal strips	4 x crocodile clips
- (around 3-4 cm long, 1 cm wide)	
acidic electrolyte, e.g.	250ml beaker
- dilute phosphoric or acetic acid	
- OR try cola or vinegar!	tissue paper
aluminium foil	
3 x 9V batteries or variable voltage power supply	tweezers

Safety

Wear gloves throughout the experiment. **DO NOT connect more than 3 batteries in series as this could be dangerous.** If you are using a variable voltage power supply, do not apply more than 30 V.

Method

1. Pour 100 ml electrolyte into the beaker
2. Cut a piece of aluminium foil slightly larger than your titanium metal strip
3. Using a crocodile clip, connect the **negative terminal** of the battery/power supply to the **aluminium**, as shown in the diagram.
4. Put the aluminium foil into the beaker, making sure it is below the level of the electrolyte.

Applying 9 V

5. If you are using a variable voltage power supply, adjust the voltage to 9V.
6. Connect the **positive terminal** of the battery/power supply to the titanium strip.
7. Using tweezers to hold the metal, lower the titanium strip into the electrolyte. **Be careful not to let the titanium touch the aluminium.** Leave in the electrolyte for 30 seconds.
8. Remove the titanium strip and use a **tissue** to remove any electrolyte. What colour is it now?

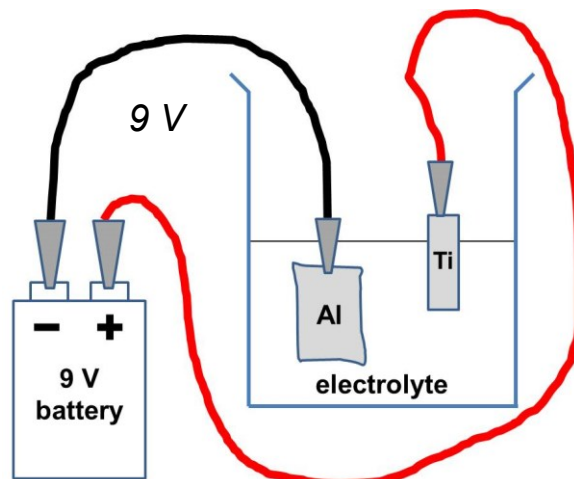

Applying 18 V

9. If you are using a variable voltage power supply, simply adjust the voltage to 18 V.

10. To achieve a higher voltage using batteries, we can connect two batteries together in **series** using a crocodile clip as shown in the diagram.

11. Connect the **positive terminal** of the *second* battery to the titanium metal strip using a crocodile clip.

12. Lower the titanium strip into the electrolyte. **Be careful not to let the titanium touch the aluminium.** Leave in the electrolyte for 30 seconds.

13. Remove the titanium strip and dry with a tissue. What colour is it now?

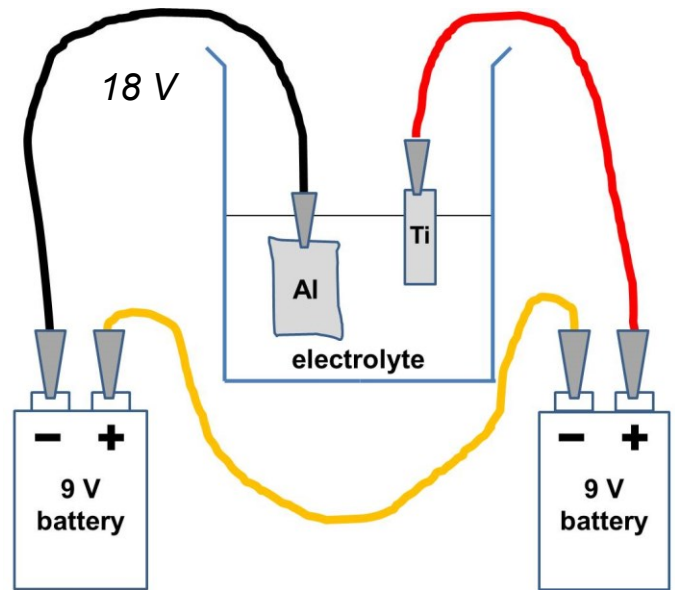

Applying 27 V

14. If you are using a variable voltage power supply, simply adjust the voltage to 18 V.

15. If you are using batteries, connect a third battery using the diagram to help you.

16. Immerse another piece of titanium in the electrolyte for 30 seconds.

17. Remove the strip, dry with tissue paper and compare with the other 2 pieces.

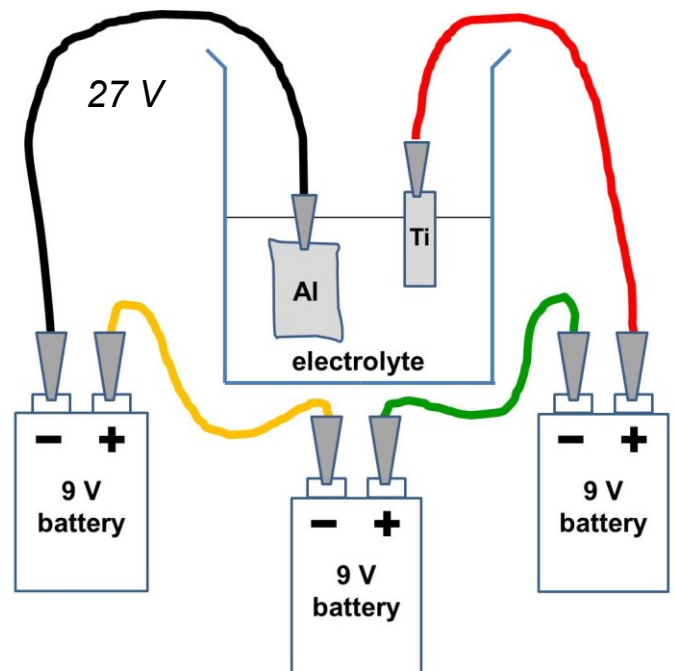

Questions

- What happens if you connect negative terminal of the battery to the titanium and the positive terminal to the aluminium?
- Try holding the titanium in the electrolyte for different lengths of time. Does it make a difference?
- Experiment with different electrolytes and strengths of acid. Which works the best?

Clearing up

Pour the electrolyte down the sink with plenty of water. The pieces of titanium and aluminium can be disposed of in the bin.